

# Little GIANT<sup>®</sup>

## Pump Company

### 5-ASP SERIES



#### Features

- Automatic or manual operation
- Epoxy coated die-cast aluminum housing
- Oil-filled motor
- 26.3' maximum lift
- 380 watts
- 1" FNPT discharge
- Thermal overload protection
- ASP On level: 6"-9", Off level: 1"-4"
- ASP-LL On level: 2"-3", Off level: ½"-1 ½"
- Piggyback diaphragm switch
- For submersible use only

#### Construction

- Motor — 1/6 HP Oil Filled
- Intermittent Liquid Temp. up to — 120° F
- Intake — Screened
- Discharge — 1" MNPT
- Housing — Epoxy coated cast aluminum
- Cover — Epoxy coated cast aluminum
- Volute — Nylon
- Impeller — Nylon
- Shaft Seal — Viton<sup>®</sup>
- Screen — Nylon

Automatic/Manual submersible utility pump with oil-filled motor and epoxy coated cast aluminum housing. For commercial, industrial and home applications where liquid must be transferred or recirculated. Pumps down to 1/8". This 1200 GPH pump features a 1" FNPT discharge with garden hose adaptor, 26.3' shut-off head capability, and screened inlet.

# Little Giant Pump Co.

## 5-ASP SERIES

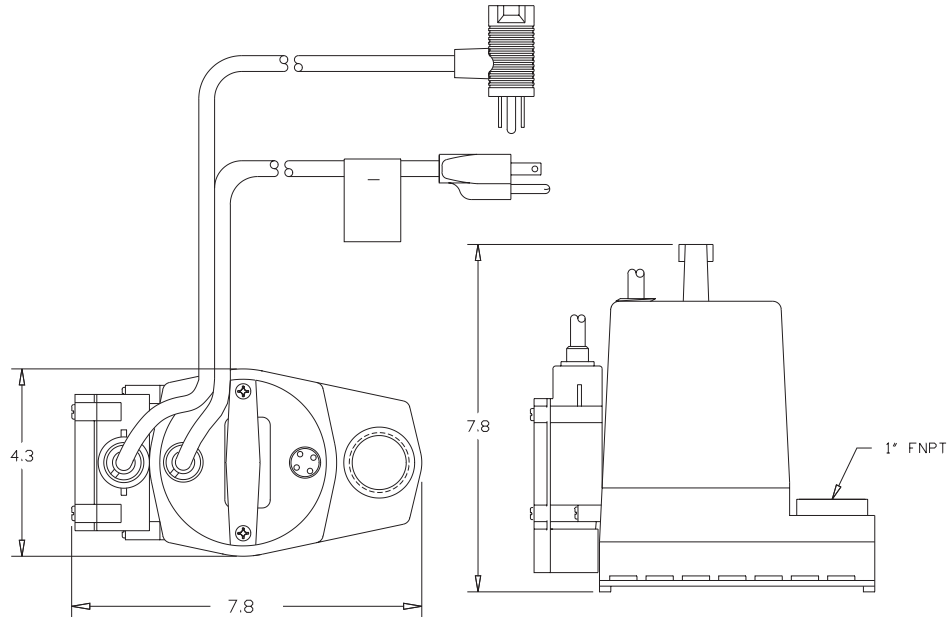

### Specifications

Model No.	Item No.	Discharge	Intake	Listing(s)	HP	Volts	Hertz	Amps	Watts	Performance (GPH @ Head)					Shut Off		Pwr. Cord (ft)	Weight (Lbs.)
										1'	3'	5'	10'	20'	Feet	PSI		
5-ASP	505300	1" FNPT	Screened	UL/CSA	1/6	115	60	5.0	380	1200	1170	1100	1000	520	26.3	11.4	10	9.00
5-ASP-LL	505350	1" FNPT	Screened	UL/CSA	1/6	115	60	5.0	380	1200	1170	1100	1000	520	26.3	11.4	18	10.00

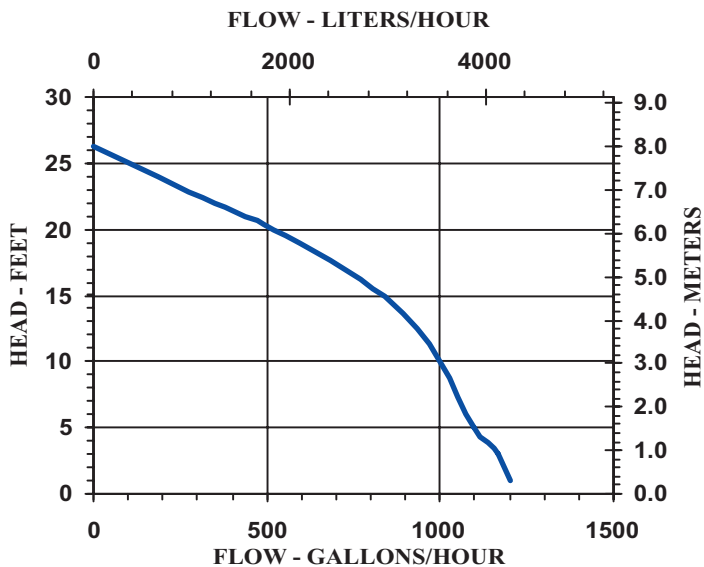

### Replacement Parts

Volute	105200
Screen	105900
Impeller	105310
Handle	105911
Adapter (GH)	599030
Seal Ring	928024

**Little Giant Pump Co.**  
 PO Box 12010  
 Okla. City, OK 73157  
 Phone: 405.947.2511  
 Fax: 405.228.1550  
[www.LittleGiantPump.com](http://www.LittleGiantPump.com)